



MRX SERIES

HIGH CAPACITY EMERGENCY LIGHT



PROJECT: _____
 FIXTURE TYPE: _____
 LOCATION: _____
 CONTACT/PHONE: _____

PRODUCT DESCRIPTION

The MRX High Output Series is an indoor emergency lighting unit with 54W capacity utilizing a sealed lead-calcium battery in 6 or 12 VDC. Supplied with two various wattage halogen MR16 or optional LED lamps which provide increased spacing, additional run-time and/or increased remote capacity. The integrated lamp design offers greater protection from vandalism.

PRODUCT SPECIFICATIONS

CONSTRUCTION

Injection molded, engineering-grade, UV-retardant thermoplastic • UL94V-0 flame rating • Impact, scratch, and corrosion-resistant • Snap-fit housing and mounting plate • Universal mounting plate with quick-connect feature reduces installation labor • White or black textured finish

ELECTRICAL

Dual voltage 120/277VAC • Solid state charging and switching • Brownout protection • Battery low voltage disconnect • Overload and short circuit protection • AC power indicator and test switch • Low voltage disconnect prevents battery from deep discharge • Offers 26W of remote capacity (6V/12V DC output) when using standard 12W halogen lamps.

LAMPS

Supplied with 6V or 12V, 12W MR16 halogen bi-pin lamps

HEADS

Includes two adjustable lighting heads • Contemporary semi-recessed round head design • High performance chrome-plated metallized reflector and plastic lens for optimal light distribution • Adjustable lamp heads provide optimal center-to-center spacing.

BATTERY

Maintenance-free 6V sealed lead calcium battery • Standard battery will operate fixture plus 26W of remote load for a minimum of 90 minutes in the event of a power outage (total of 50W load maximum)

CODE COMPLIANCE

UL924 • UL Listed for Damp Locations (20°C – 40°C) • NFPA 101 Life Safety Code compliant • NEC and OSHA compliant.

WARRANTY

5-year warranty on housing and electronics. 1-year on battery. Product specifications subject to change without notice.

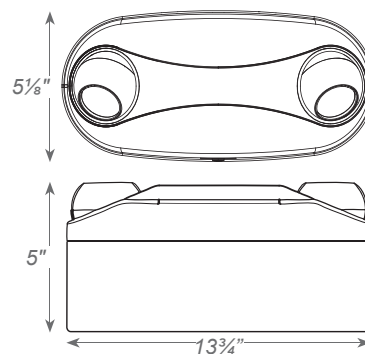

INSTALLATION

MOUNTING

Suitable for wall mounting • Surface mount via easy connect back plate, which fits most standard junction boxes and snaps into place making internal electrical connections • Conduit mount knockout on top of housing and backplate.

ORDERING INFORMATION

model	voltage	wattage	lamps	options	accessories
MRX-HO	6 = 6 Volt	54 = 54 Watts	HAL = 2 x 12W Halogen	BL = Black Housing	VRS3 = Polycarbonate Vandal Shield
	12 = 12 Volt		LED = 2 x 3.3W LED	USA = Assembled in USA	WG5 = Wire Guard
			LED = 2 x 5W LED		



Ordering Example MRX-HO-12-54-HAL



MRX SERIES

HIGH CAPACITY EMERGENCY LIGHT



PROJECT: _____
 FIXTURE TYPE: _____
 LOCATION: _____
 CONTACT/PHONE: _____

PHOTOMETRICS

Luminaire MRX (Single Head EM)

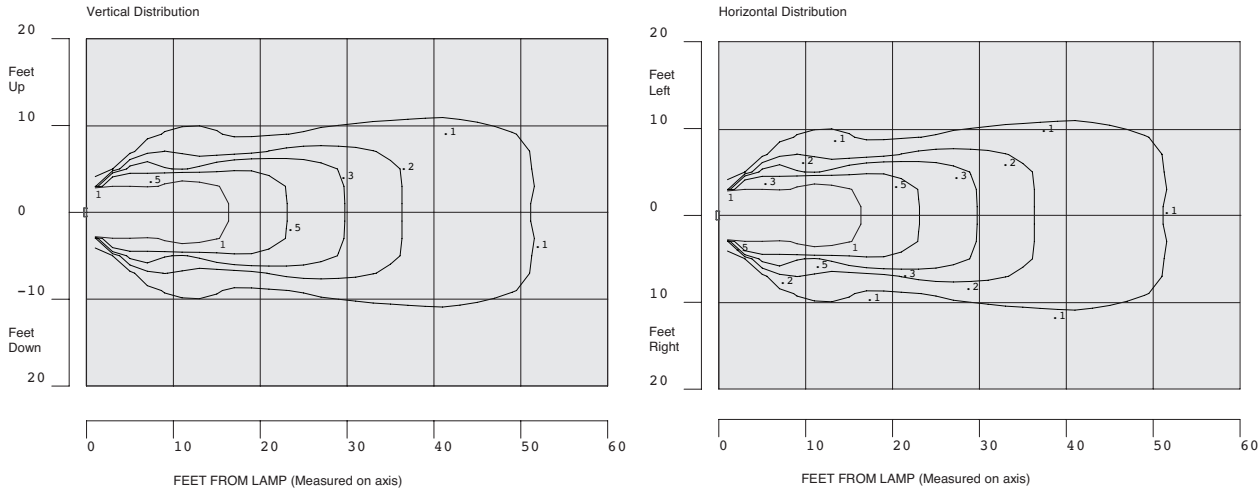

BATTERY DATA

- Lead Calcium battery warranted for one full year with additional 4 years pro-rated warranty
- Recharges in 48 hours

Type	Battery Voltage	Shelf Life ¹	Expected Life ¹	Temperature Range ²
Lead ACID (HO option)	2x6V, 10Ah	15 months	5 years	40°F - 95°F

¹ At 77°F

² To obtain rated life and capacity.

ENGINEERING DATA

	Input Voltage	Max. Amps	Max. Watts	Standby Watts
Standard	120	0.12	12.0	2.0
Fixture	277	0.05	12.0	2.1